

PREVENTIVE MAINTENANCE SUPPLEMENT

GENERAL

This supplement provides intermediate preventive maintenance information for the RSP-2150. Intermediate preventive maintenance for the RSP-2150 consists of cleaning and lubricating the transport assembly.

WARNING

Always disconnect power from the RSP-2150 before performing any preventive maintenance.

CAUTION

This equipment contains ESDS devices. Proper ESDS device handling procedures must be followed. Refer to the ESDS DEVICE HANDLING information at the front of the User's Guide for more information.

NOTE

Operator's preventive maintenance for the RSP-2150 is provided in chapter 3 of the RSP-2150 User's Guide.

MATERIALS REQUIRED

The common materials required to perform the maintenance procedures that follow include a metric Phillips head screwdriver, needle nose pliers, disposable towels, cotton swabs, and compressed air (less than 20 psi).

In addition to the common materials, an Intermediate Level Maintenance Kit (Metrum P/N 16823295-002) is also required for intermediate level preventive maintenance. The maintenance kit contains the following items:

- Compressed Air Duster (Canned Air) (Metrum P/N 16823265-001).
- Cotton Gloves (Metrum P/N 16823289-001).
- Cotton swabs (Metrum P/N 16773434-002).
- ESD Strap (Disposable) (Metrum P/N 16823268-001).
- * • Head Cleaning Cloth (Metrum P/N 10857069-00).
- * • Head cleaning solution (Metrum P/N 16823278-001).
- * • Lint-free Soft Cloth (Metrum P/N 16823291-001).
- * • Molytone Grease MOR265 (Metrum P/N 16823279-001).
- * • Replacement internal cleaning roller assembly (Metrum P/N 18002464-00).
- Scanner head chamois cleaning swabs (Metrum P/N 16819926-035).
- * • Spindle Oil (high quality) (Metrum P/N 16823288-001).

TRANSPORT LUBRICATION

The recommended lubrication/cleaning interval for the RSP-2150 transport is once every 1,000 hours of record/reproduce time (or 20,000 cartridge loads) using the recommended maintenance kit described previously. The transport may need to be lubricated/cleaned more often as conditions warrant (dependent on operating environment, tape quality, etc).

The transport assembly is lubricated before cleaning using the following instructions. Figures 1, 2, and 3 illustrate transport lubrication.

CAUTION

This equipment contains ESDS devices. Proper ESDS device handling procedures must be followed. Refer to the ESDS DEVICE HANDLING information at the front of the User's Guide for more information.

CAUTION

AC Head Assembly alignment is very critical and fragile. When performing maintenance on the Transport Assembly, make certain that the AC Head Assembly is not moved.

1. Verify that a data cartridge is not loaded (eject if necessary).
2. Set the RSP-2150 POWER switch to OFF and disconnect all power and interconnecting cables.
3. If rack mounted, remove the RSP-2150 from the rack and place on a hard flat surface.
4. Remove the top cover (20 screws).
5. Remove the following cables from the Head Amplifier Assembly.
 - 2-pin cable on left side & 6 pin cable.
 - 6-pin cable on right side
6. Remove the following cables from the Transport Control Circuit Card.
 - ribbon cable towards front
 - 8-pin cable towards rear
7. Remove BIT Synchronizer Circuit Card.
8. Loosen two captive screws and remove Transport Assembly.
9. Place the Transport Assembly on a clean flat surface away from the main chassis.
10. Using compressed air (less than 20 psi)
 - remove dust from the main chassis (pay particular attention to the fan area).
 - remove dust from the upper and lower transport areas.
11. Carefully set the Transport Assembly upside-down on a clean flat surface.

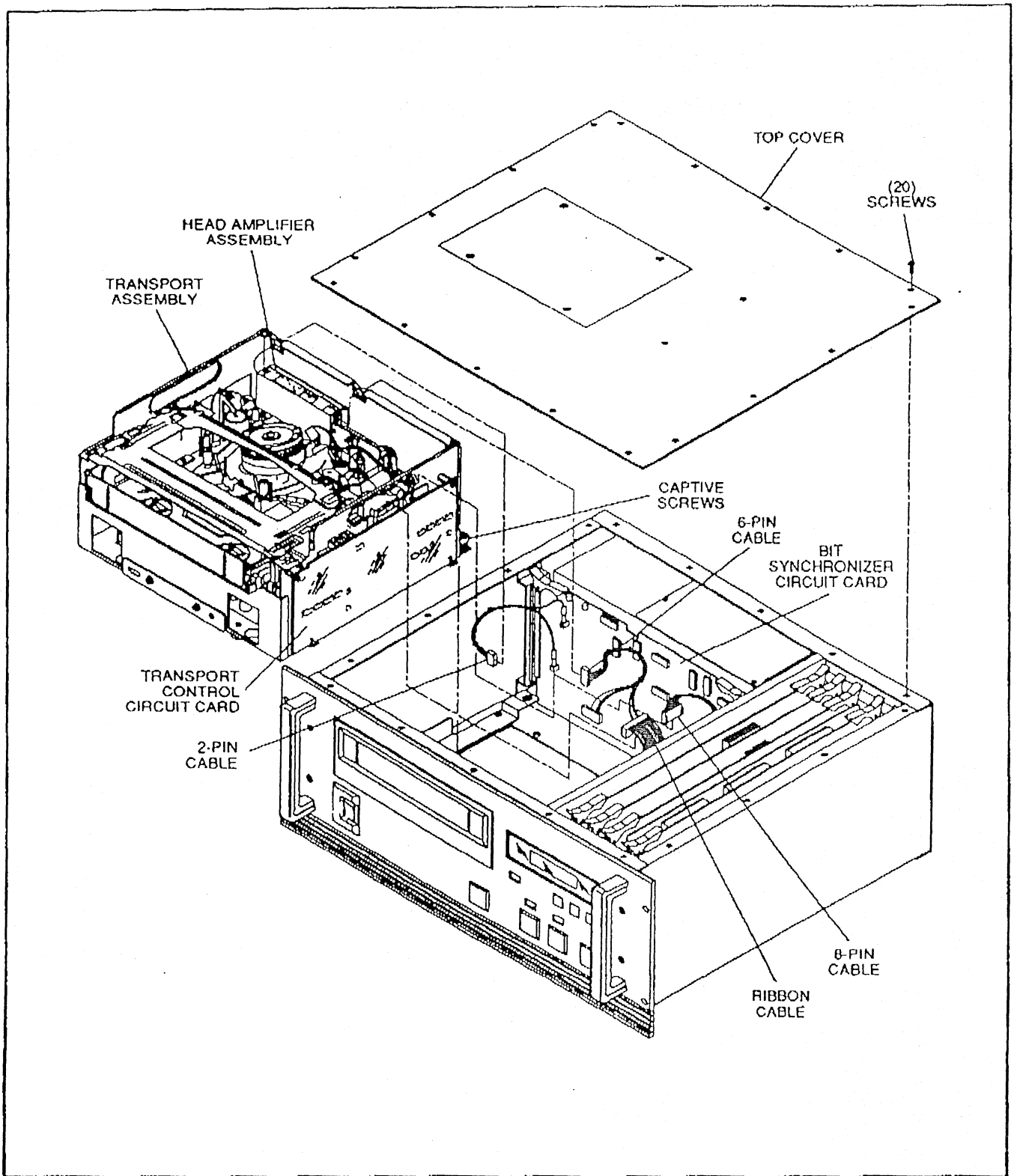

Figure 1. Transport Assembly Removal

12. Remove three screws (Figure 2, step 1) and carefully lift Servo Circuit Card (hinged).
13. Remove the following cables from the RMJC Circuit Card.
 - 3-pin cable at P1406
 - 3-pin cable at P1405
 - ribbon cable at P1403
 - 6-pin cable at P1402
 - ribbon cable at P1404
 - ribbon cable at P1401
14. Remove the RMJC Circuit Card (three screws).

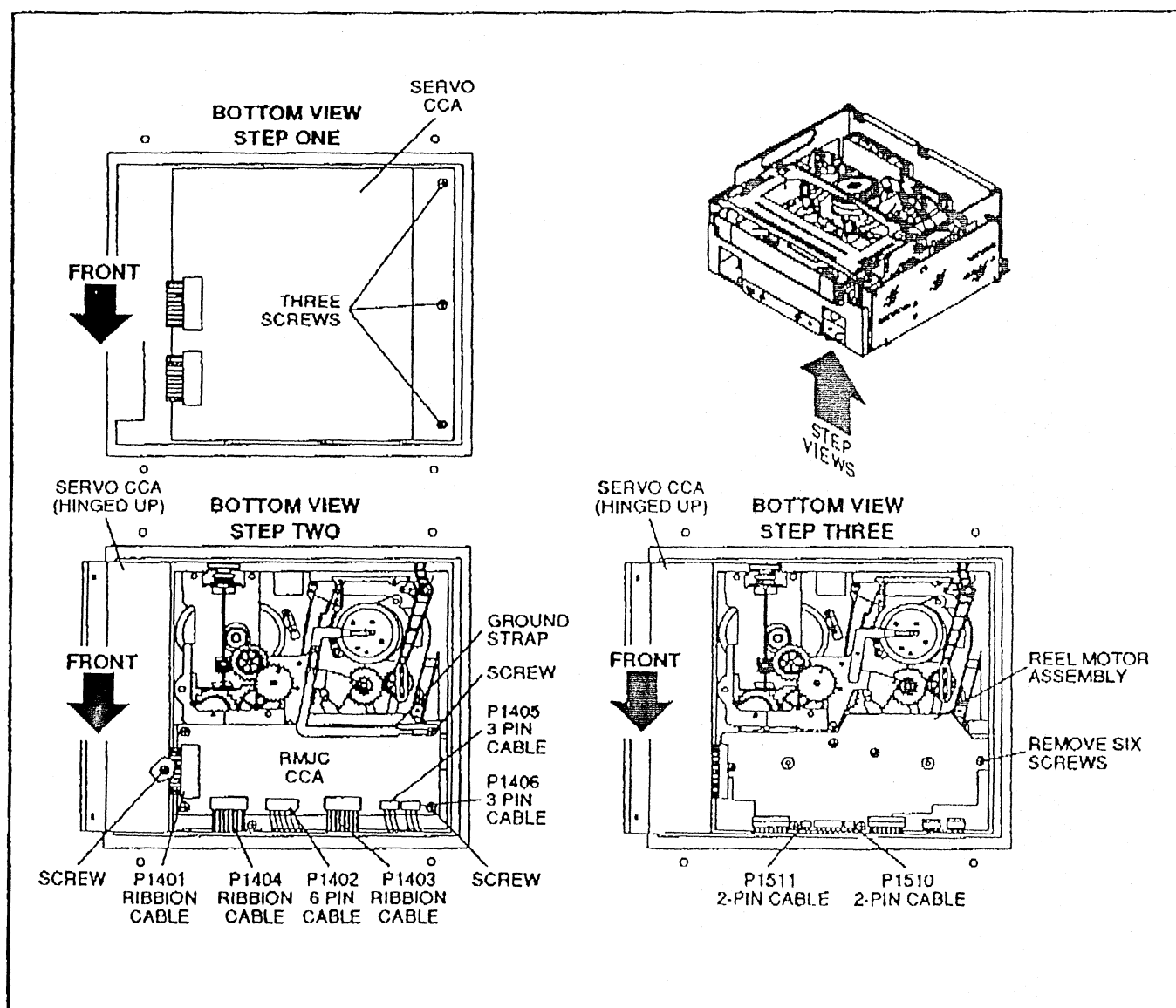

Figure 2. Lubrication Access

15. Using a disposable towel and/or cotton swabs remove old grease from the following points (see Figure 3). Gears can be moved by physically rotating the loading motor shaft at the belt.
 - Worm gear assembly
 - Main cam gear (teeth and slide slot)
 - Loading cam gear (teeth and slide slot).
 - residual grease from slots, plates, and bases.
16. Remove the following cables from the Reel Motor Assembly.
 - 2-pin cable at P1511
 - 2-pin cable at P1510
17. Remove the Reel Motor Assembly (six screws) and place on a clean flat surface.
18. Release the break then remove the supply and takeup reels (held on by magnetic field).
19. Using a disposable towel and/or cotton swabs remove old oil from the supply and takeup reel shafts.
20. Using a disposable towel and/or cotton swabs and head cleaning solution, clean the supply and takeup reel hubs (where breaks contact).
21. Apply one or two drops of high quality spindle oil to the supply and takeup reel shafts (see Figure 3).
22. Reinstall the Reel Motor Assembly (reverse steps 16 through 18).

NOTE After installing the Reel Motor Assembly it is necessary to release (open) the breaks using a small screwdriver (see Figure 3).

23. With the Transport Assembly upside down, use the wood end of a cotton swab to apply Molytone (MOR265) grease to the following points. Gears can be moved by physically rotating the loading motor shaft at the belt. Do not over grease.
 - Worm gear, teeth of driving gears, and driving gear shaft.
 - Main cam gear teeth and slide slot.
 - Loading cam gear teeth and slide slot.
 - Loading cam gear teeth and slide slot.
 - Entire length of both incline base slots (small amount).
24. Reinstall the RMJC Circuit Card and SERVO Circuit Card (reverse steps 12 through 16).
25. Carefully turn the Transport Assembly over so that the top is facing up.
26. Using a disposable towel and/or cotton swabs remove old grease from both incline base slots. Bases can be moved from the unloaded position by physically rotating the loading motor.

28. When finished, move bases to the unloaded position (full forward) by rotating the loading motor.

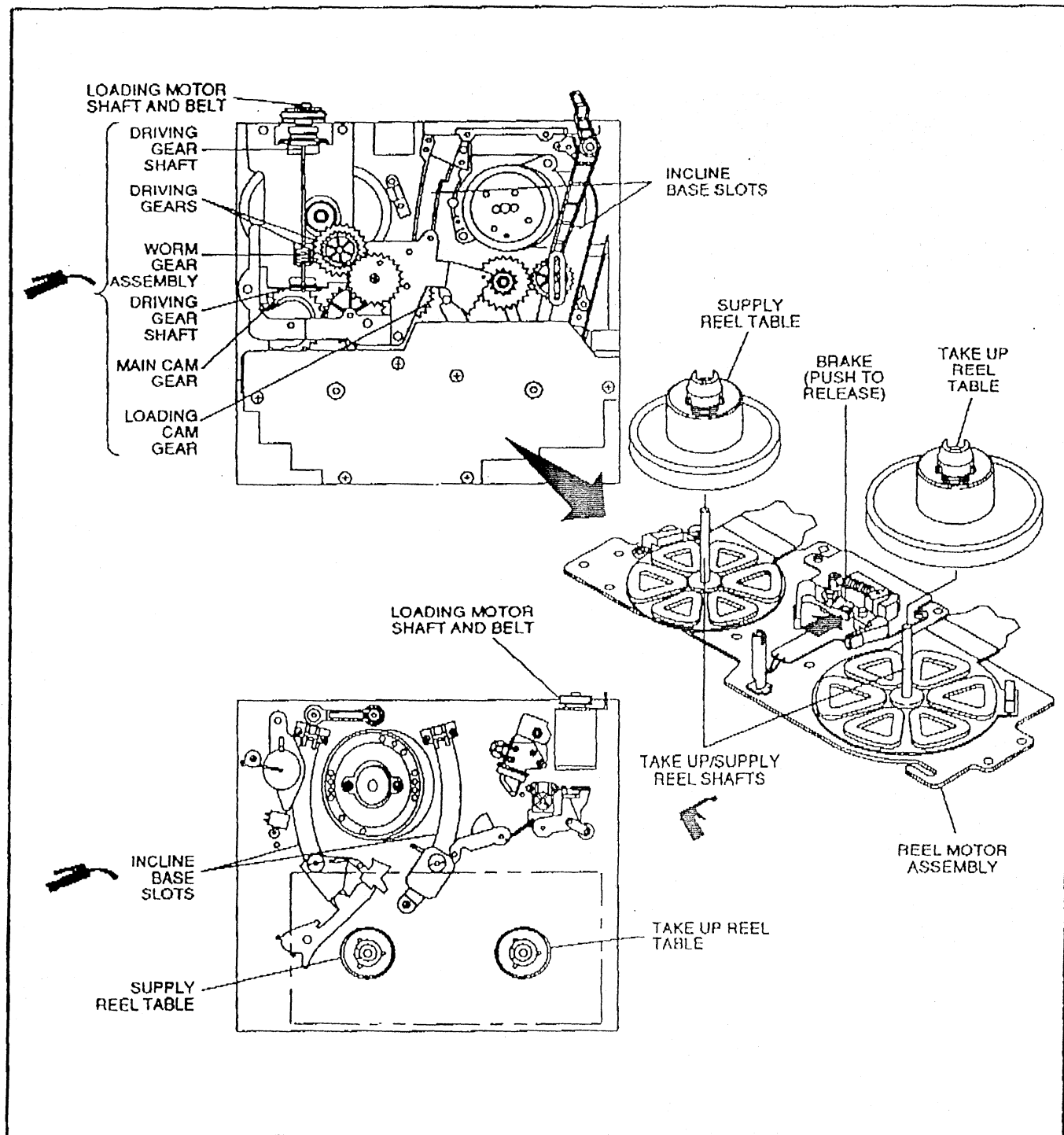

Figure 3. Lubrication Points

TRANSPORT CLEANING

The transport assembly is cleaned using the following instructions. Figure 4 illustrates transport cleaning.

CAUTION

This equipment contains ESDS devices. Proper ESDS device handling procedures must be followed. Refer to the ESDS DEVICE HANDLING information at the front of the User's Guide for more information.

1. Verify that the Transport Assembly has been removed and lubricated using the instructions provided previously.
2. Put on the cotton gloves provided in the maintenance kit.

CAUTION

DO NOT allow the head cleaning cloth or chamois swab to come in direct contact with the scanner EXCEPT as described below. Any other contact can cause permanent damage to the scanner heads.

3. Saturate a CLEAN UNUSED head cleaning cloth with HEAD CLEANING SOLUTION. Place the head cleaning cloth against the scanner drum as shown in Figure 4. DO NOT place the head cleaning cloth or chamois swab directly on the heads.
4. Rotate scanner assembly COUNTERCLOCKWISE (CCW) about three turns while holding the head cleaning cloth firmly in place. This will cause heads to contact cloth in the same manner they contact the tape. DO NOT move the head cleaning cloth while rotating the scanner assembly.
5. Stop rotating the scanner assembly at any point the head cleaning cloth will NOT rest on the heads. Note that the holes on the top of the scanner drum correspond with location of the heads. Remove the head cleaning cloth and inspect for foreign matter.
6. Repeat steps 3 through 5 using CLEAN parts of the head cleaning cloth until no foreign matter is removed from the scanner heads.
7. Using a the head cleaning cloth (or chamois swab for hard to reach areas) and head cleaning solution, clean the following transport parts (in the order given):

- ~~Upper scanner drum (DO NOT CONTACT HEADS)~~
- Lower scanner cylinder (DO NOT CONTACT HEADS)
- A/C head assembly, all heads
- Erase (FE) head
- Impedance roller
- Capstan shaft
- P1 through P5 tape guide posts
- Supply reel table
- Takeup reel table

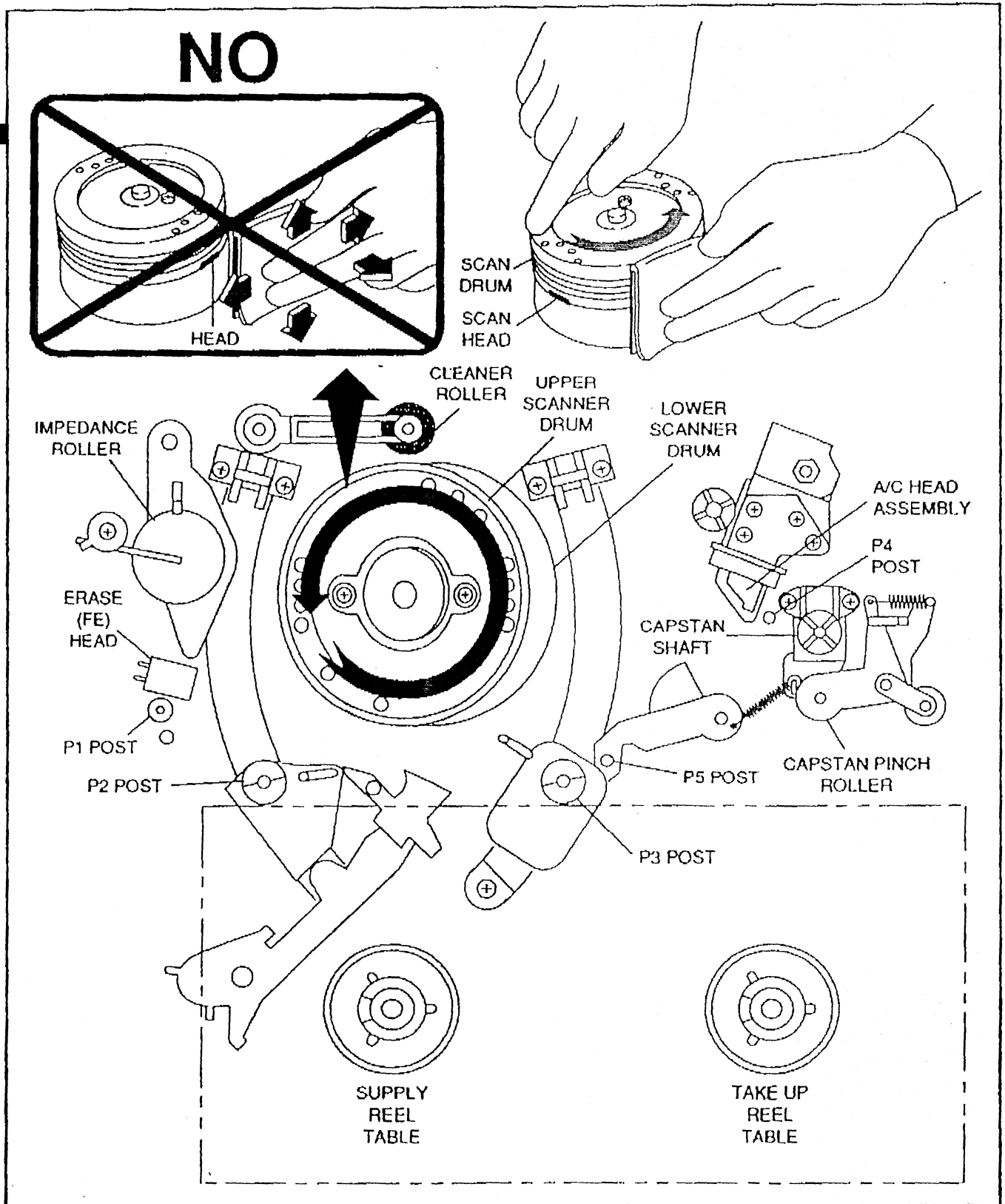

Figure 4. Cleaning Points

- Using a dry clean lint free cloth, clean the transport capstan pinch roller.

CAUTION

DO NOT USE head cleaner on the capstan pinch roller.

- Using a lint-free soft cotton cloth and head cleaning solution, clean remaining parts (elevator, loader, etc) as required.

CLEANING ROLLER REPLACEMENT

The cleaning roller is replaced after the transport has been cleaned and lubricated using the following instructions. Figure 5 illustrates roller replacement.

CAUTION

This equipment contains ESDS devices. Proper ESDS device handling procedures must be followed. Refer to the ESDS DEVICE HANDLING information at the front of the User's Guide for more information.

- Verify that the transport has been cleaned and lubricated using the instructions provided previously.
- Disconnect the 2-pin cable from the left side of the Head Amplifier Assembly.
- Remove two screws and terminal lugs, then pull the Head Amplifier Assembly from the unit (connector is at the bottom).

CAUTION

DO NOT contact scanner heads when removing cleaning roller.

- Remove cleaning roller assembly (one screw).
- Install replacement cleaning roller assembly by reversing steps 2 through 4.
- Reinstall the Transport Assembly and Top Cover (reverse Transport Lubrication steps 1 through 8). Torque screws to 8 kg/cm.

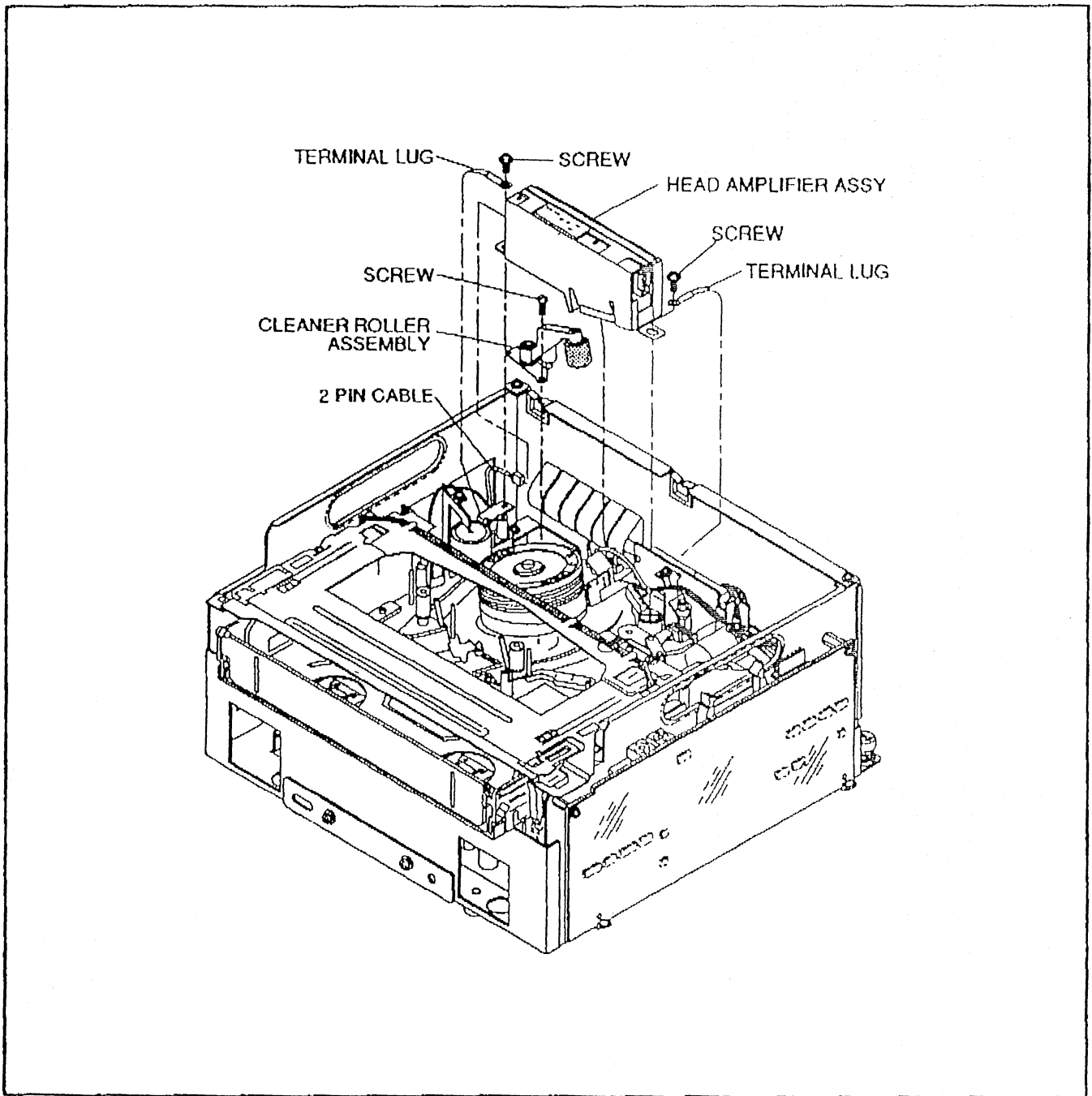

Figure 5. Cleaning Roller Replacement